

Your partner for maximum
efficiency, reliability, and
long-term performance

Propeller & aft ship **solutions**



Everlence



Leading the transition

With Everllence's propeller and aft ship solutions, plus the expert support of our global team, you can set a confident course towards net zero shipping.

For more than 250 years, Everllence has been at the forefront of technology innovation. Today, our engines power more than half of global seaborne trade, supported by class-leading propulsion solutions that trace their lineage back to the first Alpha controllable pitch propeller in 1902.

International shipping accounts for a significant share of global greenhouse gas emissions, and regulatory, commercial, and societal pressure to decarbonize is accelerating.

You can wait for compliance to dictate your next move. Or you can lead by optimizing and future-proofing your engines, propellers, and propulsion systems, improving efficiency today while preparing for tomorrow's environmental standards.

A legacy of trust



From diesel engines to breakthrough propulsion and turbomachinery technologies, Everllence has a heritage of "world first" innovations.

Today, we support thousands of shipowners and operators across every ocean with solutions built on performance, reliability, and long-term partnership.

Moving big things to zero

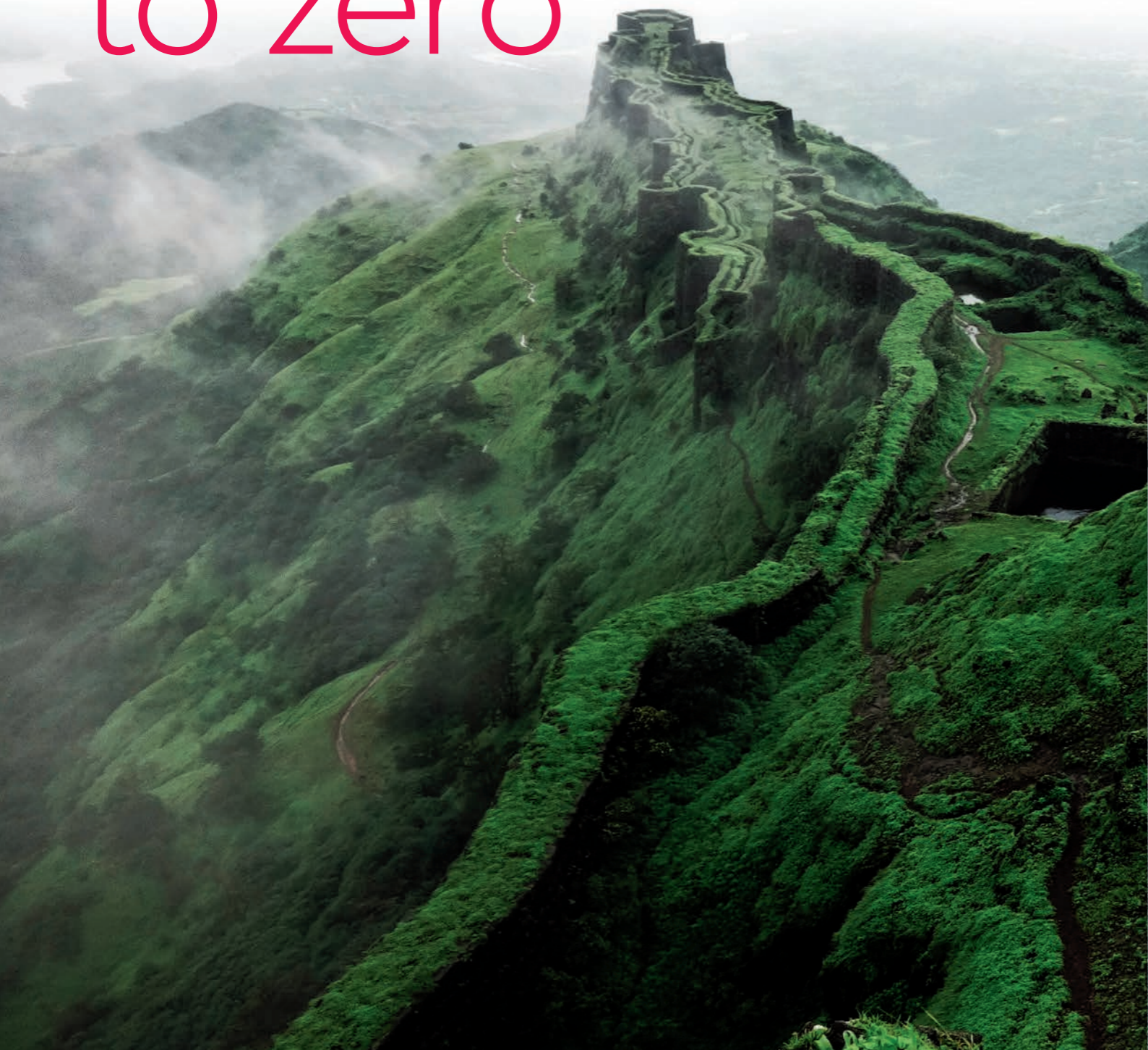

The world is changing faster than ever. Rising demand for energy and transport, combined with mounting climate pressure, is accelerating the shift towards low- and zero-carbon solutions.

Moving big things to zero is our commitment to decarbonizing the industries that keep the world turning, with no compromise to performance.

For shipping, this means helping you reduce emissions now through proven efficiency measures, while preparing your vessel for tomorrow's fuels, regulations, and flexible operational demands.



As your partner, we deliver tailored propulsion and aft ship solutions built around your specific vessel, route profile, and commercial priorities, backed by engineering expertise and lifecycle support.

Together, we can pave the way for a climate-neutral and economically successful future.

Let's get started.

Harnessing the power of wind

Wind-assisted ship propulsion (WASP) generates thrust from wind energy using rotor sails, wing sails, suction sails, or kites to reduce fuel consumption and emissions.

A recent example of this in action is the state-of-the-art CO₂ carrier **Northern Pioneer**, where Everllence harmonized the main propulsion system to operate at optimal efficiency while integrating WASP to leverage free and abundant wind power.



Solutions for your operational needs

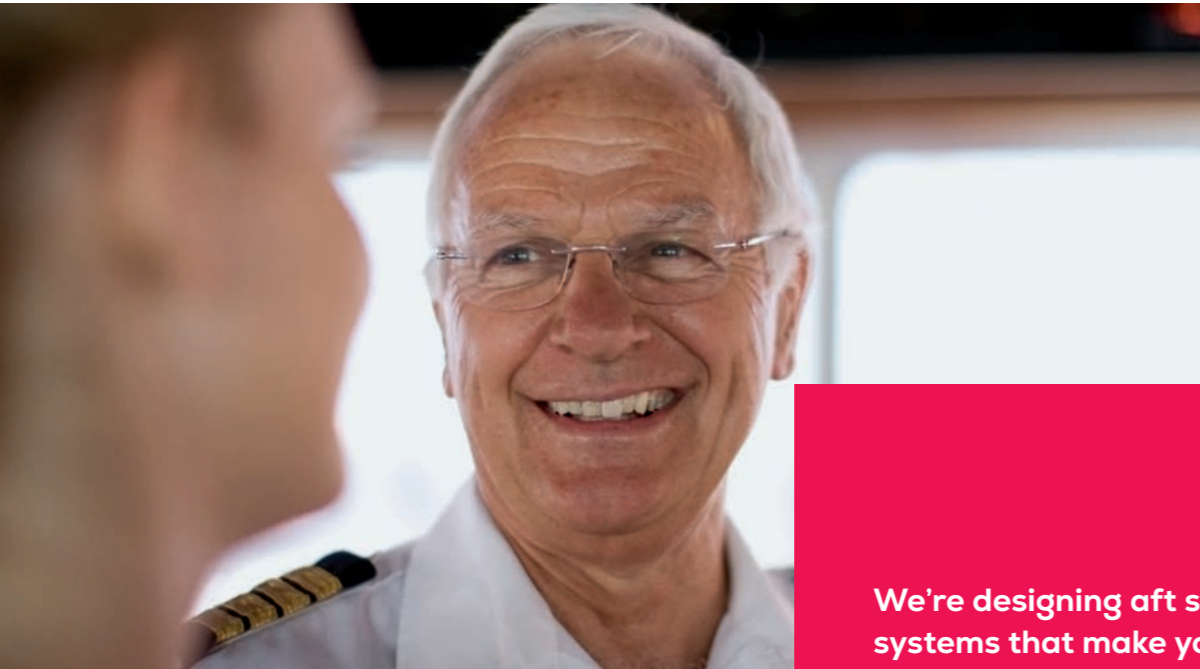

We're designing aft ship systems that make you ready for new propulsion concepts, regulations, and expectations without starting over.

By integrating hydrodynamically-advanced propeller design, engine performance, and digital control, we help you design vessels that are efficient today and ready for the demands and regulations of tomorrow.

Our systems cover a wide range of operating profiles, from slow-steaming bulkers and shock resistant naval vessels, to ferries and Ro-Ro vessels with high service speeds, so you can keep your options open.

From vision to vessel

- **Future-fuel-ready propulsion** – engines and controls that can already operate with low carbon fuels, with upgrade paths toward 100% hydrogen and other green fuels.
- **Smart aft ship integration** – propellers, rudder bulbs, struts, gearboxes, shaft lines, and control systems engineered as a unified ecosystem for maximum efficiency and responsiveness.

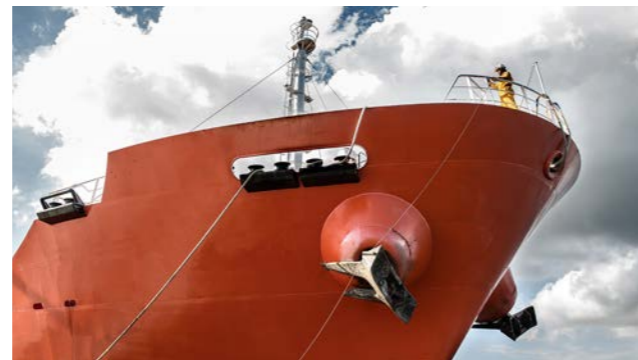

- **Propellers and propulsion systems** – for flexible powertrain concepts from wind-assisted propulsion systems and diesel/electric prime movers to hybrid systems.
- **Digital integration** – intelligent software and data analytics that help you operate smarter, more efficiently, and more securely with greater reliability and predictability.

Pushing the limits of performance



Global support

15,000+ employees across 140+ locations and 100+ service centers are ready to support your needs, with a trusted production network in Europe and Asia.

Moving big things to zero is about more than adopting low-carbon fuels – it's about pushing every component to perform better, with more thrust from every kilowatt, smoother operations in tougher conditions, and dependable uptime.

As a trusted provider of efficient, integrated drive and energy solutions for shipowners and operators worldwide, we cover the full marine propulsion chain, including propellers, aft ship solutions, shaft lines, and propulsion control systems.

Decades of expertise means we can optimize your propulsion systems to diverse ship operating profiles and the individual needs of your operational and business requirements.

We also ensure that performance does not stop at delivery. With Everllence PrimeServ, our global aftersales service, we support you around the clock and around the world with OEM-quality spare parts, maintenance, retrofits, and digital monitoring for continuous optimization.

"We are constantly rethinking propeller and aft ship designs and integration, so your fleet runs more efficiently, cleaner, and for longer across its entire lifecycle."

Propulsion systems that save fuel and lower emissions



Our high-efficiency propeller and aft ship solutions are engineered for both newbuilds and retrofit upgrades, delivering measurable gains in fuel economy, maneuverability, and operational reliability.

Efficient propulsion requires more than an optimised engine. It demands precise interaction between propeller geometry, shafting, aft ship hull lines, and control systems.

Everllence develops integrated aft ship solutions that convert engine power into thrust with maximum hydrodynamic efficiency and minimal vibration, cavitation, and noise.

Our Alpha controllable pitch (CPP) and fixed pitch (FPP) propellers are tailored to each vessel's operational profile. For retrofit projects, upgraded blade designs and modern control systems unlock additional performance gains without major structural changes.

By increasing propulsive efficiency across the entire load range, we help reduce fuel consumption, lower emissions and improve lifecycle cost performance.

Reliability is the highest priority
Whatever your vessel's mission or operating environment, Everllence propulsion systems are built to perform when failure is not an option.

Propelling you forward

Tailored to each application

Every vessel operates under unique and dynamic conditions, from high bollard pull or high speed and rapid load changes to silent, low-vibration cruising. Future-proofing your propulsion performance depends on matching propeller design precisely to key parameters, such as hull form, wake field, and operational demand.

Our specialists will ensure you have the optimal propeller solution, including blade geometry, diameter, pitch distribution and material selection to give maximum thrust efficiency and durability.

Engineered for demanding environments

More than 7,500 Alpha propellers have been delivered worldwide, for environments ranging from shallow inland waterways to polar ice classes, and offshore conditions. Robust hub designs, high-strength materials and proven hydraulic pitch systems ensure long service life under harsh mechanical and environmental stress.

Comprehensive propulsion coverage

Our Alpha propeller portfolio covers a wide range of vessel types and power requirements, supported by shafting solutions and advanced Alpatronic propulsion control systems.

Contents

Everllence system expertise

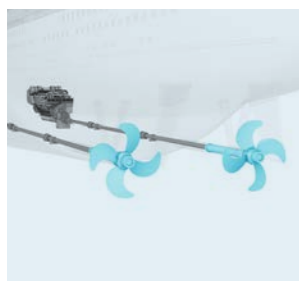

Propulsion optimization **14**

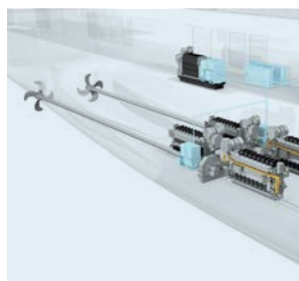

Hybrid propulsion **18**

Alpha propeller and aft ship solutions



Controllable pitch propellers **20**



Fixed pitch propellers **24**

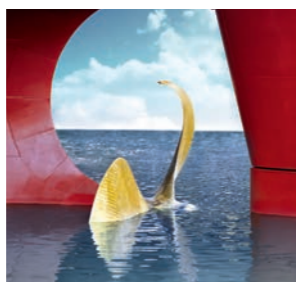

Kappel 2.0 designs **28**



Efficiency improving devices **32**



Clean shipping is the future **36**



Underwater Radiated Noise **38**

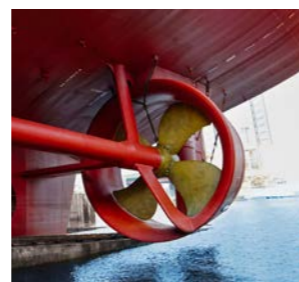

Propeller nozzles **40**

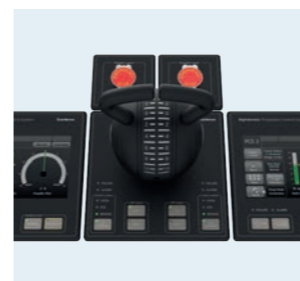

Alphatronic 3000 **44**

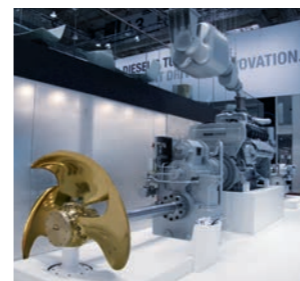

System competence **48**



Retrofit and upgrade - CPP **54**

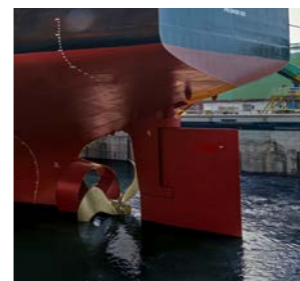

Retrofit and upgrade - FPP **56**

Everllence PrimeServ

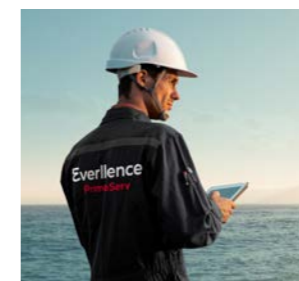

Service with passion **58**



Worldwide service **60**

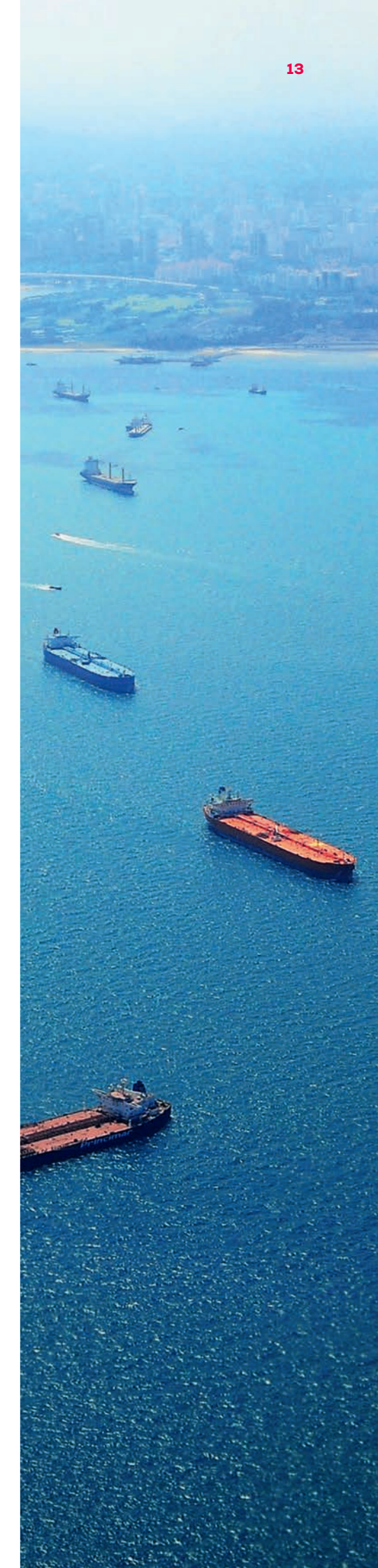

Turning power into movement

Propulsion optimization

Propulsion optimization is about converting engine output into thrust with the highest possible efficiency across the vessel's operating conditions.

Starting from a detailed analysis of your ship's operational profile (speed range, load patterns, route characteristics, and maneuvering requirements), our engineering specialists optimize the complete propulsion chain. This includes the gearbox, PTO/PTI, shaft line, propeller blades, nozzle, rudder interaction, and propulsion control system.

By ensuring that every component is matched and harmonized, we reduce fuel consumption, improve load response, minimize vibration and maximize overall propulsive efficiency, not just at design speed, but across the full operating range.

Comprehensive system expertise
Everllence combines Alpha propellers and aft ship systems with specialized gear solutions and advanced propulsion control to deliver integrated propulsion packages from a single source.

The result is a balanced system engineered for efficiency, reliability and long-term performance.

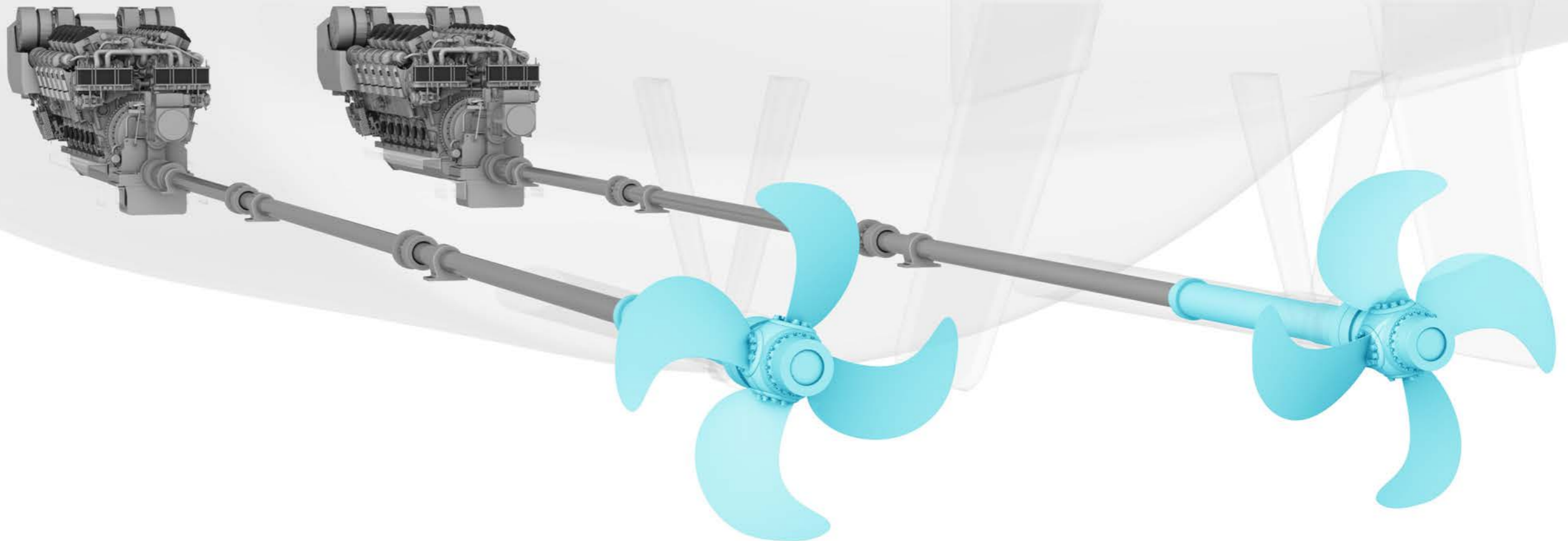

Because every ship is different

Propulsion optimization

Your vessels operate under specific conditions, defined by route, load profile, maneuvering requirements, and commercial priorities. Propulsion optimization begins with analyzing these factors to ensure that every component is configured to deliver maximum efficiency in real-world operation.

We work with leading gearbox manufacturers to integrate solutions such as power take-off (PTO), power boost (PTI), take-home (PTH), and hybrid concepts, ensuring flexibility and redundancy where required.

The Alphatronic 3000 propulsion control system coordinates engine speed, propeller pitch and auxiliary functions to optimize maneuverability and fuel economy under all operating conditions.

Benefits

- Integrated propulsion package from one source
- Solutions matched to your vessel's operational profile
- Optimized efficiency across the full operating range

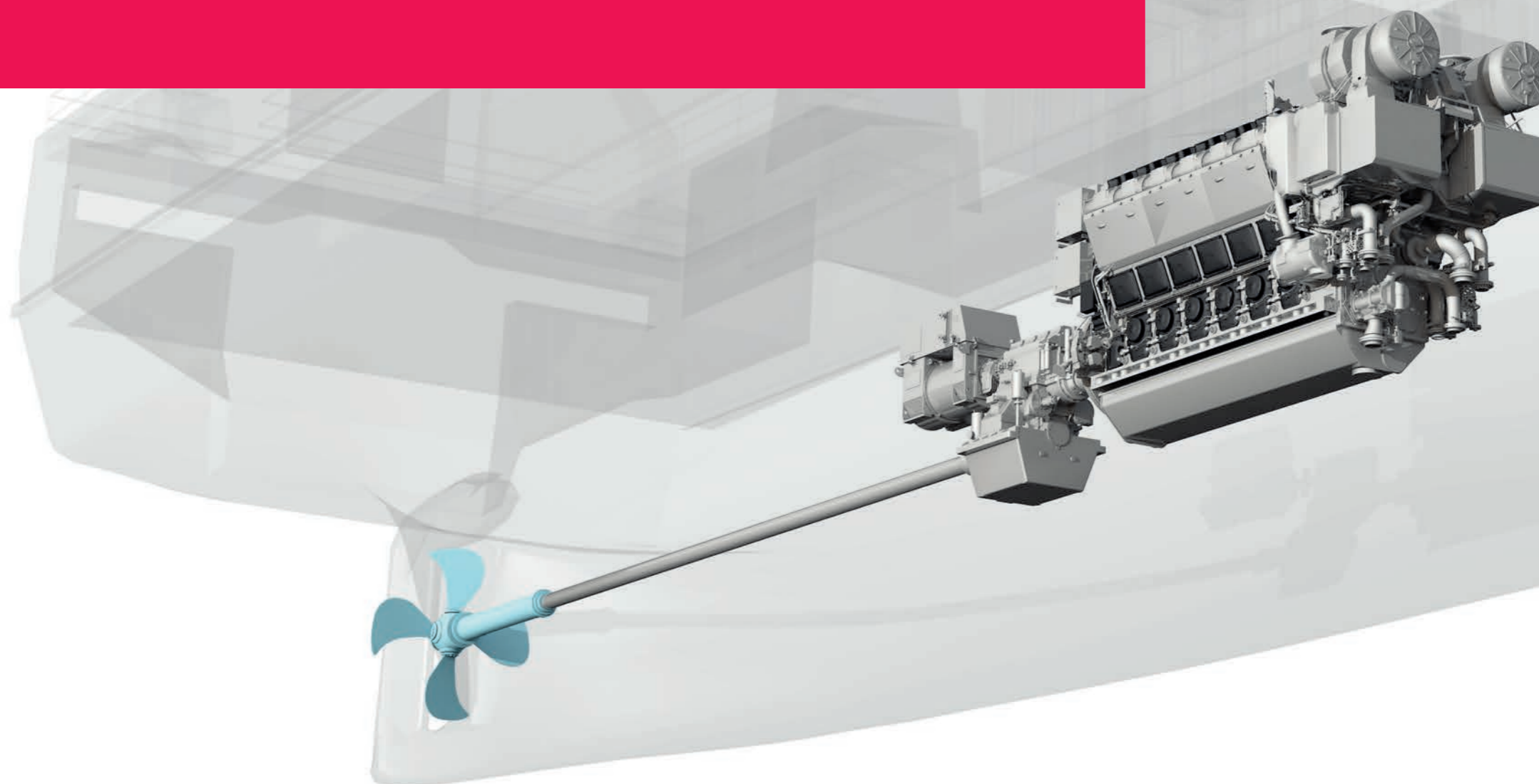

Alternative routes to cost-effectiveness

Hybrid propulsion

Hybrid propulsion combines mechanical and electrical power to match energy supply to operational demand.

By allowing diesel engines, electric motors, and power systems to work together, hybrid configurations optimize fuel efficiency across variable load profiles.

Flexibility and efficiency combined

The integration of mechanical drive and electric power enables multiple operating modes. Vessels can run on mechanical propulsion for high-efficiency cruising, electric power for low-load or low-noise operation, or a combination of both when additional thrust is required.

Everllence delivers fully tailored hybrid propulsion and power generation solutions, integrating main engines, GenSets, switchboards, converters, electric motors, gearboxes, and propellers into a single system. Each configuration is designed around the vessel's specific operating pattern to ensure optimal performance and reliability.

Battery integration

Battery energy storage systems add further flexibility by enabling peak shaving, spinning reserve, silent operation, and load leveling. This reduces fuel consumption, maintenance requirements, emissions, and noise, while improving overall system efficiency and operational resilience.

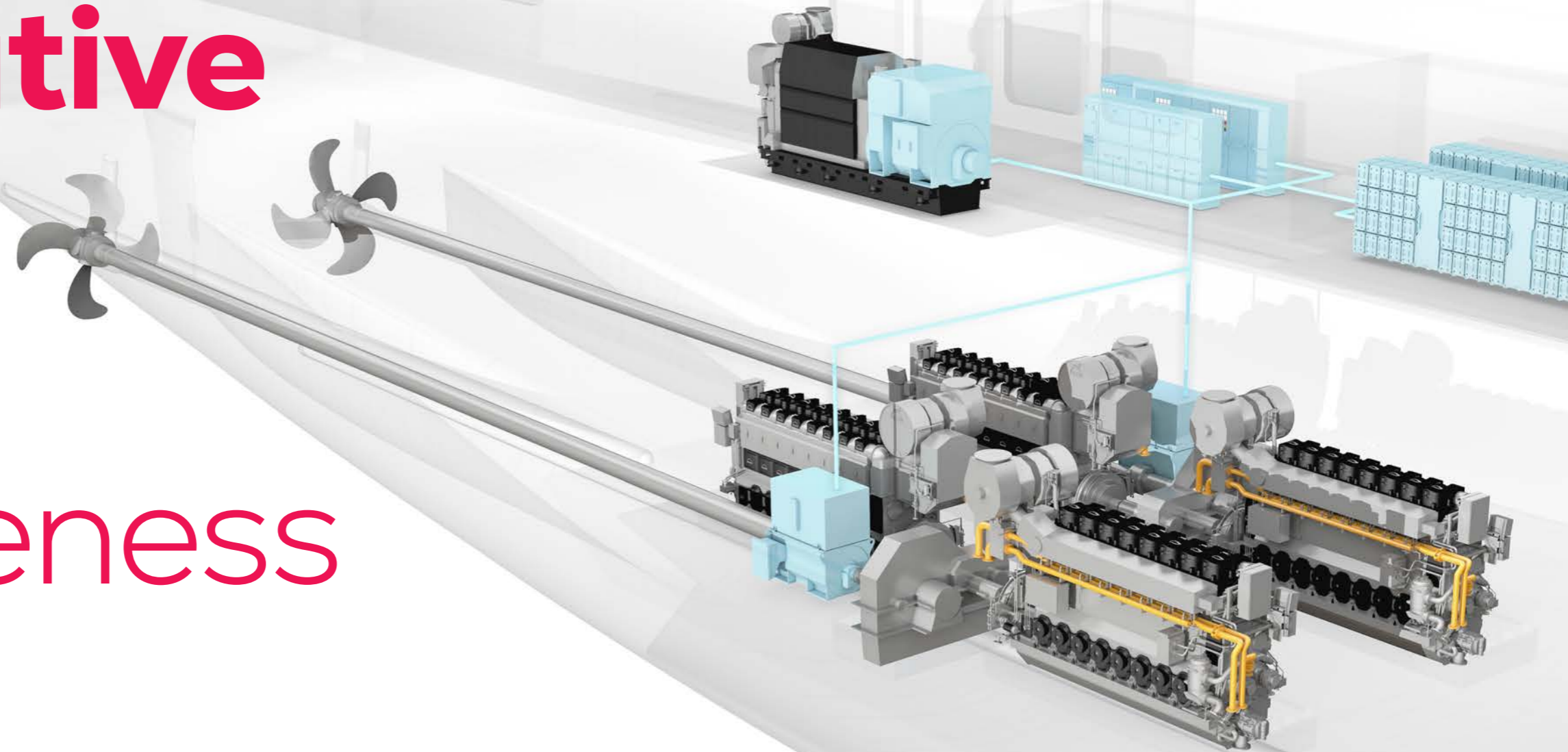

Controllable pitch propellers

Engineered for your performance needs

The Alpha controllable pitch propeller (CPP) range covers power outputs of up to 40,000 kW per shaft line. With 23 hub sizes available, each installation can be precisely matched to the required power level and operational profile, ensuring an optimal balance between performance and cost.

The standard configuration features four blades, with three- and five-bladed variants available where specific hydrodynamic or acoustic requirements apply. Additional designs allow for full-feathering pitch capability when required.

Standard blade and hub materials are Ni-Al-Bronze, with stainless steel available as an option. For demanding operating environments, the propellers can be ice-strengthened and tailored to meet specific class requirements, including the highest polar ice classes.

Integrated shaft line solutions

Complete shaft line systems, including tail shafts, intermediate shafts and bearings, are customized to suit a wide range of vessel applications. Stern tube lubrication and sealing systems can be configured for mineral oil, biodegradable oil or water-lubricated arrangements, depending on operational and environmental requirements.

Special features for naval applications

For specialized demands, such as full feathering propellers, hydroacoustics, silent operation, shock resistance, flooded, and black ship operation, cross-over between engine rooms, or Integrated Logistic Support (ILS), read our naval propeller brochure or scan/click the QR code below:



Power, flexibility, and maneuverability

Controllable pitch propellers

Efficient propulsion across changing operating conditions

Alpha CPPs are ideally suited to vessels with variable propulsion demands, from dynamic maneuvering to economical part-load operation and full-speed steaming.

The variable and adaptive propeller pitch control give optimized thrust and power consumption over the full operating range, considering dynamic factors like hull conditions, draft, trim, waves, and wind. Together with (PTO/PTI) consumers or contributors, this results in high efficiency, reduced fuel consumption at minimal vibration and noise levels.

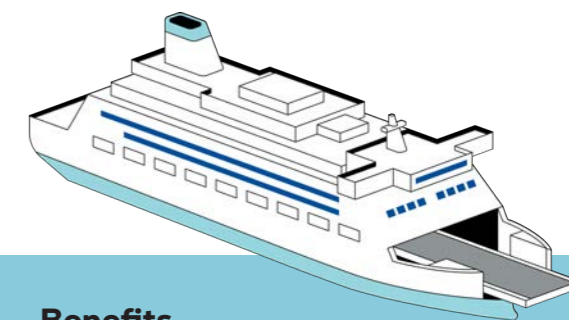

Benefits

- **Fuel and emissions savings**
High propulsion efficiency means low fuel consumption and less exhaust gas emissions
- **Propulsion flexibility and highest overall efficiency**
Cutting-edge hydrodynamic blade designs for top propulsion performance and versatility across operating profiles
- **High comfort for passengers and crew**
Reliable operational efficiency with controlled cavitation, reduced pressure pulses, and low noise levels
- **Low wear rates**
Long product lifetimes from high quality materials and robust component designs with ample strength margins

Applications

- Container feeder vessel
- Coastal tanker / Shuttle tanker
- Ro-Ro vessel / RoPax vessel
- Dredger
- LNG tanker
- Yacht
- Ferry
- Cruise
- Workboat
- Naval defense
- Ice breaker
- Offshore
- Fishing
- Research/survey
- Chemical tanker



Fixed pitch propellers

Customized solutions based on robust, high-efficiency designs

The Alpha fixed pitch propeller (FPP) range is designed to match the full Everllence engine portfolio. The series is available in 3-, 4-, 5- and 6-bladed monoblock configurations, cast as a single piece with integrated hub and blades for maximum strength and reliability.

Standard material is Ni-Al-Bronze, with alternative alloys available on request to suit specific operating conditions.

For demanding applications, including high ice-class vessels, tailored FPP designs are available with bolted replaceable blades or bolted adjustable blades. Replaceable blade concepts allow blade exchange without docking, while adjustable blades provide the option to fine-tune the fixed pitch setting to operational requirements.

A new-generation FPP with flanged hub-to-shaft connection is also available.

Integrated shaft line solutions

Complete shaft line systems, including tail shafts, intermediate shafts, bearings, shaft alternators, couplings and associated components, are customized and optimized to match the individual powertrain and vessel.

Robustness and efficiency

Fixed pitch propellers

Long-haul propulsion with lowest operational costs

Alpha FPPs are the preferred choice for vessels where maximum efficiency and robust simplicity are paramount. They are ideally suited to ocean-going ships operating on steady long-haul routes at or near their design speed, where fixed pitch configurations achieve peak propulsive efficiency.

With their straightforward, durable design and minimal mechanical complexity, FPPs offer high reliability and low lifecycle costs.

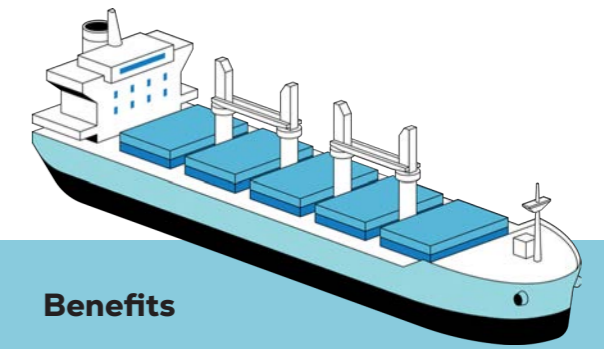

Benefits

- Lowest Total Cost of Ownership**
 Operational savings are achieved through a highly efficient, mechanically simple design with few wearing parts, engineered for durability, reliability, and long service life
- Minimum fuel consumption and emissions**
 Optimized propeller efficiency reduces fuel consumption and associated exhaust gas emissions across steady operating conditions
- Efficiency by design**
 The superior efficiency from the streamlined and smallest hub diam./propeller diam. ratio is exploited with due respect to controlled cavitation, pressure pulses and noise

Applications

Container vessel
 Crude oil tanker
 Bulk carrier
 Product tanker
 Dry cargo vessel
 Chemical tanker
 Car carrier
 Arctic OPV
 Offshore



Kappel 2.0 designs

A unique blade geometry for higher efficiency

Everllence offers the fuel-saving Kappel 2.0 blade design for both fixed pitch and controllable pitch propellers, making the full Alpha propeller range available with Kappel designs.

Kappel blades are also well proven in retrofit upgrades. Numerous monoblock FPPs have been replaced with Kappel designs, and CPPs from other manufacturers have successfully been upgraded with Kappel blades to improve efficiency.

Inspired by nature

Inspired by the wingtip features found in nature and aviation, the smoothly curved blade tip reduces energy loss from tip vortex flow, improving lift and overall propulsive efficiency.



In a class of its own

Kappel 2.0 designs



Optimized propulsion efficiency

Propellers equipped with Kappel blade designs are well suited to high-end vessels where efficiency, energy performance, and reduced environmental impact are prioritized.

Improved propulsive efficiency can translate into lower required engine power, reduced fuel and lower exhaust gas emissions. Alternatively, the efficiency gain may be utilized as increased thrust, enabling higher vessel speed at a given engine output.

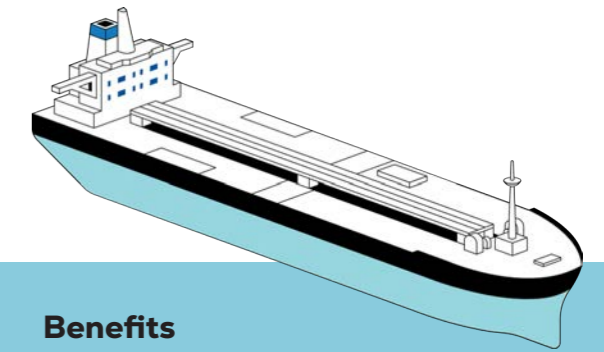

Benefits

- Reduced fuel consumption and emissions**
 Higher propulsive efficiency contributes to lower fuel use and reduced exhaust gas emissions
- Improved performance and market positioning**
 Enhanced efficiency supports EEDI and CII performance, strengthening a new or retrofitted vessel's energy rating, 'green' profile, and future readiness
- Increased onboard comfort**
 Reduced propeller-induced pressure pulses lower hull vibration and onboard noise levels
- Potential for larger propeller diameters**
 Lower pressure pulses allow reduced hull clearance margins, enabling the installation of larger, more efficient propellers where vessel design permits

Applications

Chemical tanker
 Container vessel
 Crude oil tanker
 Ferry
 Bulk carrier
 Product tanker
 Naval defense
 Ro-Ro vessel / RoPax vessel
 Dry cargo vessel
 Car carrier
 LNG tanker
 Cruise

Efficiency improving devices

Improving the flow to and from propellers

Efficient propulsion depends on more than propeller design alone. Everllence optimizes the complete aft ship arrangement to improve inflow to the propeller and reduce drag in the slipstream, increasing overall propulsive efficiency.

Our hydrodynamic integration work is tailored to the vessel's hull form and operating profile, and may include flow-guiding Efficiency Improving Devices (EIDs) positioned before, at, or after the propeller.

- **Placed before the propeller**
Pre-swirl and wake-equalizing ducts, pre-swirl fins, or vortex generators
- **Placed at the propeller**
Propeller nozzles, fairing cones, or propeller hub cap fins (EcoCap)
- **Placed after the propeller**
High-efficiency rudders and twisted rudders, integrated Alpha rudder bulbs (EcoBulb), post-swirl fins, or similar devices

Multiple EIDs can be combined with tailored propeller designs to achieve additional efficiency gains. Model testing and operational experience show that Kappel blade designs can perform in effective synergy with a range of EIDs for open propeller configurations.

Other EIDs like Wind-assisted ship propulsion (WASP) and hull air lubrication are also optimized with our propeller and propulsion control systems.

For ducted operation with propeller nozzles, Everllence blade designs are optimized specifically for pulling performance, using wide-chord geometries with extended chord lengths toward the blade tip.



EID combinations

The right configuration is essential to optimize propulsion efficiency

	Before the propeller		At the propeller			After the propeller		
	Pre-swirl fins	Wake equal. duct	Kappel design	EcoCap Hub cap fins	AHT nozzle	EcoBulb Rudder bulb	Post-swirl fins	Efficiency rudder
Pre-swirl fins		●	●	●	●	●	●	●
Wake equal. duct	●		●	●	●	●	●	●
Kappel design	●	●		●	●	●	●	●
EcoCap Hub cap fins	●	●	●		●	●	●	●
AHT nozzle	●	●	●	●		●	●	●
EcoBulb Rudder bulb	●	●	●	●	●		●	●
Post-swirl fins	●	●	●	●	●	●		●
Efficiency rudder	●	●	●	●	●	●	●	

● Can be combined ● Can sometimes be partially combined ● Should not be combined

Kappel and EIDs in perfect synergy

Proven combinations of propellers and EIDs can deliver measurable propulsion power savings. Over recent years, Everllence has built extensive experience in EID integration, supporting both newbuild installations and retrofit upgrades.

Ducted and open propellers, including low-skew, high-skew and Kappel blade designs, can be optimized to match each vessel's hull form, wake field characteristics, EID arrangement, and operating profile.

8-12%

efficiency gain from
Kappel propellers and EIDs

Kappel propeller blades optimized with pre-swirl wake equalizing duct and Alpha EcoBulb Rudder Bulb deliver efficiency increase of up to 8-12% for newbuildings – and even more for retrofit upgrade solutions.

Clean shipping is the future

Environmental requirements in shipping are tightening rapidly. Emissions and pollution risks that were once accepted are now under increasing scrutiny, driven by regulators, port authorities, the IMO, and growing expectations from shipowners, operators, and cargo stakeholders.

As a result, clean shipping criteria are becoming stricter, with greater focus on preventing pollution and minimizing environmental impact throughout the vessel lifecycle.

Designed to protect

Everllence supports this transition with leak-proof, environmentally responsible stern tube system options integrated with our propeller solutions. We offer water-lubricated stern tube arrangements, as well as systems approved for biodegradable, non-toxic lubricants.

Our water-lubricated stern tube and shaft systems can be based on epoxy coated shafts – or the more robust and durable clad-welded shafts with specific material alloys optimized for the operation and seawater environment.

All Everllence propellers can be delivered in compliance with the US EPA Vessel General Permit (VGP).

Minimizing Underwater Radiated Noise

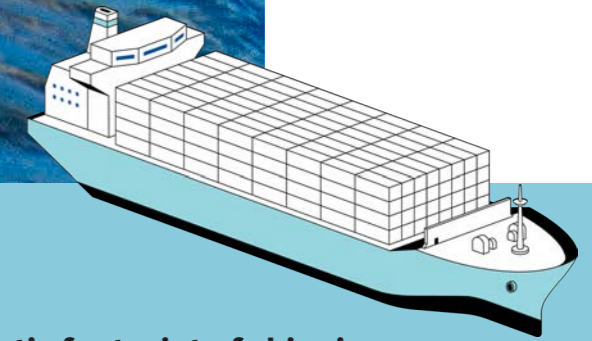

Reducing the acoustic footprint of shipping

Underwater Radiated Noise (URN) from vessels can affect marine life that depends on sound for communication and navigation, such as whales. As awareness increases and regulations evolve, shipowners are under growing pressure to reduce acoustic impact alongside emissions.

Propellers are the primary source of URN, mainly due to cavitation (the formation and collapse of vapor bubbles on the blade surface). Effective noise reduction therefore requires precise control of cavitation behavior and careful optimization of the interaction between hull, wake field, and propeller.

Engineering quieter propulsion

Everllence applies advanced hydrodynamic analysis tools, including high-fidelity CFD simulations, in-house panel codes, and acoustic prediction methods to evaluate flow patterns, predict cavitation, and assess URN performance.

By optimizing aft ship components, including rudders, struts, and appendages (and therefore the wake field quality), we refine and optimize the blade geometry and blade number for reduced pressure fluctuations and shift the balance towards quieter propulsion.

Our solutions support compliance with emerging noise guidelines and Silent class notations, while maintaining propulsive efficiency and overall vessel performance.

Propeller nozzles

Alpha High Thrust (AHT) nozzles

For vessels where maximum thrust and pulling performance are paramount, Everllence offers customized AHT nozzle designs. These nozzles are engineered to enhance bollard pull and improve low-speed propulsion efficiency for demanding operational profiles.

Compared to conventional 19A nozzles widely used in the marine industry, AHT nozzles deliver improved performance through a CFD-optimized profile with a double-curved geometry on both inner and outer surfaces.

Performance when you need it

Additional performance gains are achieved through optimized length-to-diameter ratios, integrated nozzle support structures, aft ship lines adaptation, and installation options such as nozzle tilting or azimuthing.

High-thrust and speed-optimized AHT nozzle configurations are particularly suited to vessels that require strong pulling power while maintaining low resistance during free sailing.



Extra thrust when you need it

Superior performance for heavy duty vessels

Our range of ducted propellers and AHT nozzles boost thrust for high performance vessels, enabling bollard pull, push, and towing force at very high levels. The propeller blades are specifically designed and tailor-made for optimized operation with the AHT nozzles and customized into the aft ship vessel design.

Benefits

- **More pushing and pulling power**
Increased propeller thrust, especially at lower vessel speeds
- **Reduced fuel consumption**
Required bollard pull or towing force can be achieved with lower power output and engine rating
- **Customized to the application and aft ship design**
Optimized balance of ahead and astern performance, with reduced free-sailing resistance
- **Retrofit potential with up to 23.5% higher bollard pull**
When upgrading older nozzles to the AHT design, combined with new Alpha propeller blades optimized for nozzle operation

Applications

Fishing trawler
Anchor handling tug supply
Dredger
Tug boat
Seismic research/survey
Ice navigating vessel



Alphatronic 3000

Reliable and accurate propulsion control at your fingertips



The Alphatronic 3000 Propulsion Control System provides precise propulsion control from the navigator's fingertips to the propeller tips. Maneuvering commands are translated into speed, pitch, and clutch signals, governing the hydraulic servo circuits of the engine, gearbox, and propeller system.

This gives you an intuitive and reliable human-machine interface, with ergonomically designed panels, levers, buttons, displays,

and touchscreens that support safe and efficient maneuvering.

A single solution for every setup

The Alphatronic 3000 supports both CPP and FPP installations and can be customized for a wide range of propulsion configurations using the Everllence portfolio of low-, medium-, and high-speed engines, including single- and multi-propeller diesel/mechanical, hybrid, and diesel/electric setups.

Performance from bridge to propeller

The Alphatronic 3000 is designed not only to execute commands, but to continuously optimize propulsion performance. By coordinating propeller pitch, propeller speed, and engine load, the system enhances maneuverability, improves fuel economy, and helps to protect engine and drivetrain components.

Fully customizable propulsion control

Alphatronic 3000

Examples of features and options for specific applications:

- Adaptive combinator curves
- Advanced hybrid propulsion control
- Synchro phasing of propellers
- Silent / URN mode operation
- Special fishing and workboat control modes

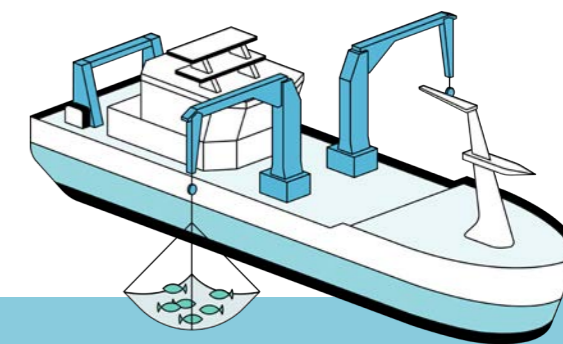

Benefits

- **Safe and reliable maneuvering**
Fast system response and precise control of speed and pitch ensure smooth, predictable vessel maneuverability under all operating conditions
- **Reduced fuel consumption and emissions**
Optimized engine load and thrust control support economical operation. Optional features such as Speed Pilot with GPS interface enable economy-sailing modes, while the EcoOptimizer concept for CP propulsion further refines fuel-saving mode selection based on vessel speed, pitch setting, and engine SFOC mapping
- **Engine lifetime protection**
Built-in overload protection and controlled run-up and run-down programs safeguard the engine against excessive thermal and mechanical stress, supporting long-term reliability

Applications

Two-stroke low-speed
 CP Propeller
 FP Propeller
 PTO
 Four-stroke medium-speed
 Twin-in single-out
 Power boost
 Four-stroke high-speed
 Single- and multi-propeller
 PTH
 Diesel-electric
 Hybrid plants



System competence

Advanced tanker design, engineered for flexibility and efficiency

Integrating every element of the powertrain and aft ship system makes it possible to unlock synergies and deliver a propulsion package optimized for both efficiency and operational flexibility.

One of our Everllence system examples for a tanker features a single-engine, single-propeller propulsion arrangement. Here, the vessel has been designed for high propulsive efficiency and prepared for multi-fuel operation on HFO, MDO, MGO, as well as LNG.

From a propeller and aft ship perspective, the vessel has been optimized with a twisted leading-edge rudder fitted with an Alpha EcoBulb rudder bulb, an Alpha 7.6-meter CP propeller with fairing cone, and an integrated stern tube and shaft system with shaft alternator, powered by a two-stroke Everllence B&W 6G60ME-GI engine.

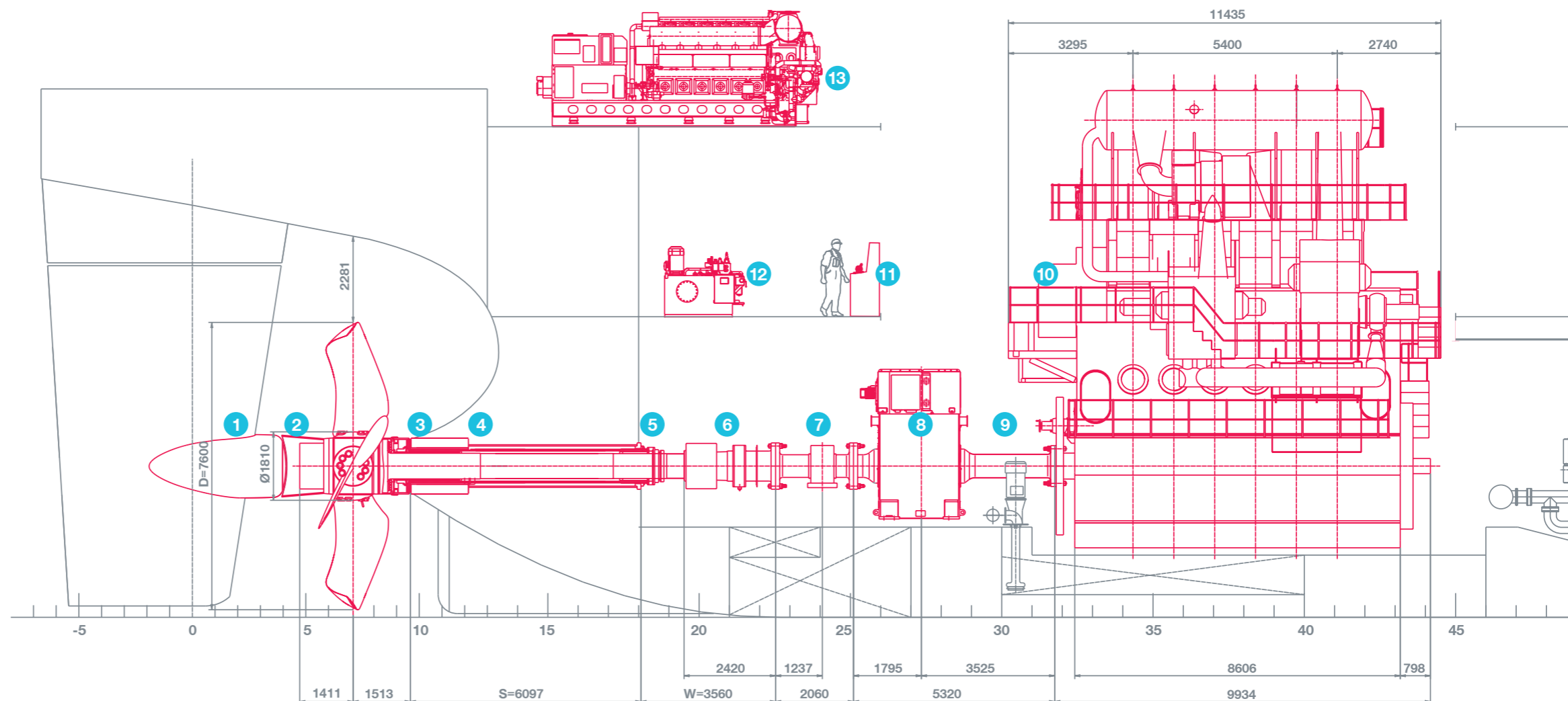

A complete propulsion and power package

- 1 Alpha designed EcoBulb rudder bulb on ship's rudder
- 2 Alpha fairing cone on propeller hub
- 3 Alpha CP Propeller, type VBS1810
- 4 Oil-lubricated stern tube with liners and aft seal
- 5 Welding ring, adaptor flange, oilbox, and forward seal
- 6 Alpha hydraulic coupling flange
- 7 Journal bearing
- 8 Shaft alternator
- 9 Rotor shaft for alternator
- 10 Everllence B&W 6G60ME-GI engine
- 11 Alphasonic 3000 propulsion control system, ECR, and bridge
- 12 Alpha Hydraulic power unit for propeller system
- 13 GenSet (4 sets in total)

Propulsion packages across the full engine range

System competence



Complete propulsion packages for all engine concepts

Everllence brings decades of experience in the engineering, optimization, delivery, commissioning, and lifecycle support of complete propulsion systems. Our propeller and aft ship portfolio integrates seamlessly with the full range of Everllence high-speed, medium-speed, and low-speed engine platforms.

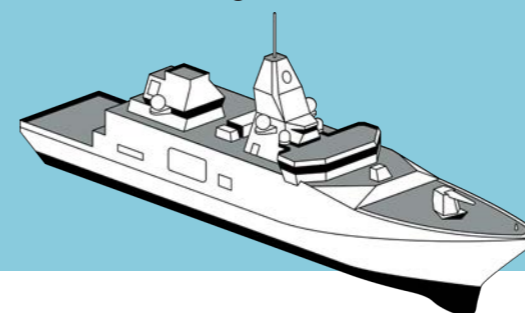

There is no one-size-fits-all propulsion concept. Each vessel demands a solution tailored to its operational profile, performance requirements, and installation constraints.

Our system expertise covers a wide range of configurations, from diesel-electric and engine-electric propulsion plants with multiple power sources, to diesel-mechanical solutions such as high-speed 175D-powered patrol vessels, 32/44CR medium-speed container ship installations, and Everllence B&W G45ME low-speed tanker propulsion.

Diesel-electric

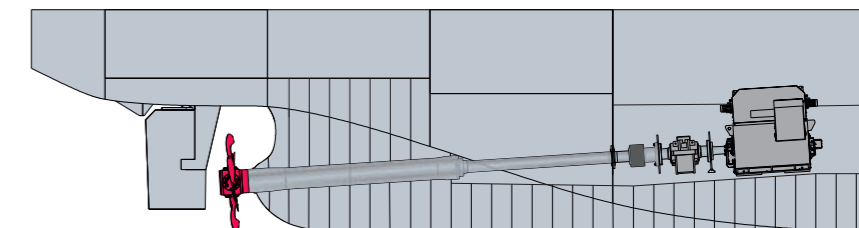

High-speed 12V175D

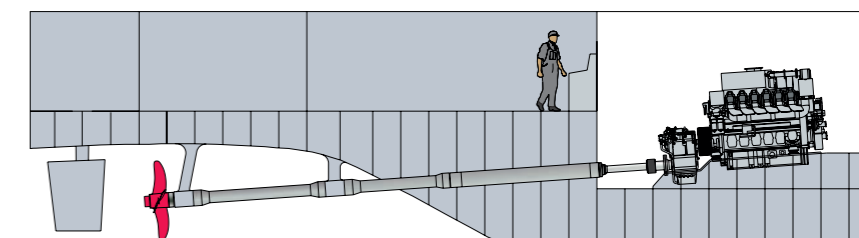

Medium-speed 6L32/44CR

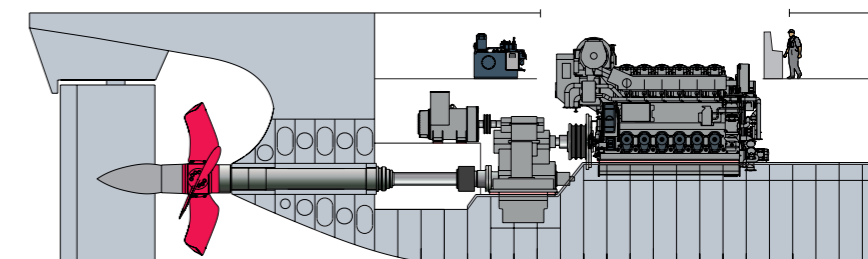

Low-speed Everllence B&W G45ME

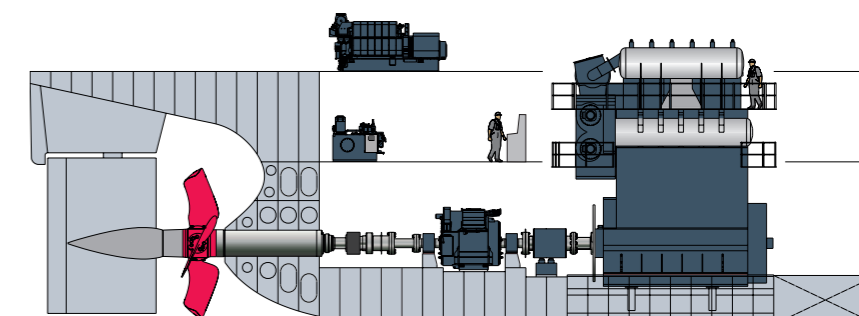

What system competence means for you



Added value for shipyards, owners and operators

With Everllence system competence, customers across the value chain benefit from reduced installation and operating costs, supported by a single point of contact through one responsible organization.

SHIPYARD

Shipyards' project benefits

- Pre-project plant conception, power and speed prediction, and propulsion package parameter estimation with a high degree of system accuracy
- System engineering based on fully integrated propulsion expertise
- Early resolution of propulsion equipment interfaces and integration matters
- Due considerations are taken to Torsional Vibration Calculations (TVCs) and special ice class requirements
- Shaft alignment and whirling calculations to ensure optimal bearing loads and positioning
- A competent contract partner throughout project planning, procurement, installation, and commissioning
- Coordinated package logistics ensuring safe delivery of all components, including consolidated deliveries aligned with installation schedules

Shipyards' order handling benefits

- Thorough pre-engineering of propeller, propulsion equipment, and control system components to minimize shipyard workload
- One consolidated documentation package covering auxiliary systems, piping, electrical wiring, interfaces, and alignment
- Dedicated commissioning engineers responsible for propulsion equipment during start-up and sea trials
- Reduced shipyard responsibility and administrative burden, minimizing engineering and installation effort

OWNER

Owners' operating benefits

- Optimized operating economy through coordinated design of propeller, aft ship, struts, stern tube, shafting system, and propulsion control system
- High reliability, durability, and predictable service intervals through a tailored, well-engineered system solution
- One organization supplying, testing, and commissioning the equipment, together with the subsequent lifetime accumulation of performance and operating experience for the propulsion components

Owners' service benefits

- One complete service documentation package, including maintenance programs and spare parts catalogs, supporting efficient service routines and parts identification
- Digital monitoring and data transmission solutions available via Everllence PrimeServ ASSIST
- One global service organization supporting all propulsion requirements through the worldwide network of Everllence PrimeServ representatives, authorized workshops, and service centers
- Service contracts available at multiple levels, from basic agreements to comprehensive long-term service agreements (LTSAs) with scheduled services performed by Everllence PrimeServ
- PrimeServ Academies providing propulsion system training for engineers, operators, and service personnel

Retrofit and upgrade – CPP

Carbon Intensity Indicator improvement from D to A

Everllence designs and delivers propulsion retrofit solutions that enhance vessel performance and efficiency.

By combining advanced hydrodynamic analysis with propulsion system expertise, we identify targeted measures that reduce fuel consumption and emissions while improving regulatory performance.

CPP, aft ship, and propulsion system case

Through a focused retrofit of the CPP, aft ship, and propulsion plant, a vessel's CII rating was improved from D to A.

The upgrade combined main engine power reduction and part-load optimization with installation of a pre-swirl wake equalizing duct, optimized Alpha propeller blades, a propeller hub fairing cone, and integration of an EcoBulb rudder bulb.

Together, these measures enhanced overall efficiency and reduced fuel consumption and emissions.

Challenge us to improve your vessel's performance

Everllence applies specific analysis to uncover retrofit potential for measurable improvements in efficiency, compliance, and long-term operating performance.

Contact us to explore your best options for your vessel or fleet.

25%
fuel savings
achieved

Retrofit and upgrade – FPP

Drive greater value from your investments over their lifetime

In many cases, efficiency upgrades and engine derating offer significant fuel-saving potential, short payback times, and the ability to improve a vessel's energy performance rating. Retrofit solutions can range from a simple propeller or blade replacement to more extensive upgrades where a holistic view of the complete propulsion plant delivers maximum value.

Everllence retrofit projects may include optimization of the entire propulsion chain, including the engine, turbocharger, PTO,

gearbox, shafting, propeller, and aft ship equipment, ensuring that all components are optimized together as an integrated system.

FPP, aft ship, and propulsion system case

One example is a retrofit program for six Suezmax tankers, where an upgrade and derating solution implemented during five-year dockings delivered 17.5% fuel savings. The complete package included a Kappel propeller, a pre-swirl wake equalizing duct, and main engine upgrades with new turbochargers and

fuel nozzles, an increased compression ratio, and optimized valve timing.

To match the new Kappel propellers, new intermediate shafts were installed to address torsional vibration behavior associated with the 3-bladed propeller configuration, shaft line, and derated engine setup. Following technical sea trials, NOx measurements were carried out on the first vessel to enable preparation of an updated IMO Technical File.

17.5%
fuel savings
achieved



PrimeServ Service with passion

Everllence PrimeServ is the dedicated Everllence service brand. Via a network of over 100 service centers worldwide, Everllence PrimeServ provides 24/7 service across the globe.

Our range of services includes technical support, consulting and OEM spares, as well as maintenance, repair and individualized service plans like our PMC, Propeller Maintenance Concept.

24 365

hours a day

days a year

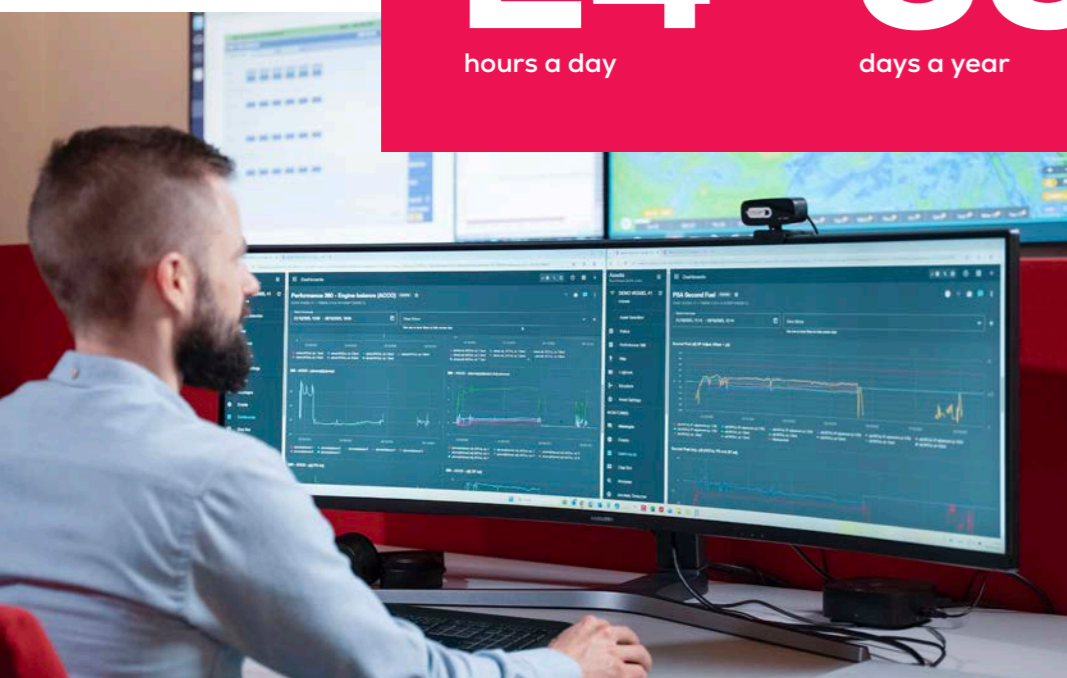

The PMC service packages for propeller maintenance are offered in connection with 5 and/or 10 year inspections, in accordance with the docking periods recommended by the classification societies.

For navy applications and more demanding operators, we can additionally offer a suite of comprehensive and advanced Integrated Logistic Support (ILS) solutions.

We will support you with:

- Prompt delivery of high-demand OEM spare parts within 24 hours
- Fast, reliable and competent customer support
- Individually tailored O&M contracts
- Ongoing training and qualification of operators and maintenance staff
- Global service, 24 hours a day, 365 days a year
- Diagnosis and troubleshooting with our high-performance PrimeServ ASSIST online service

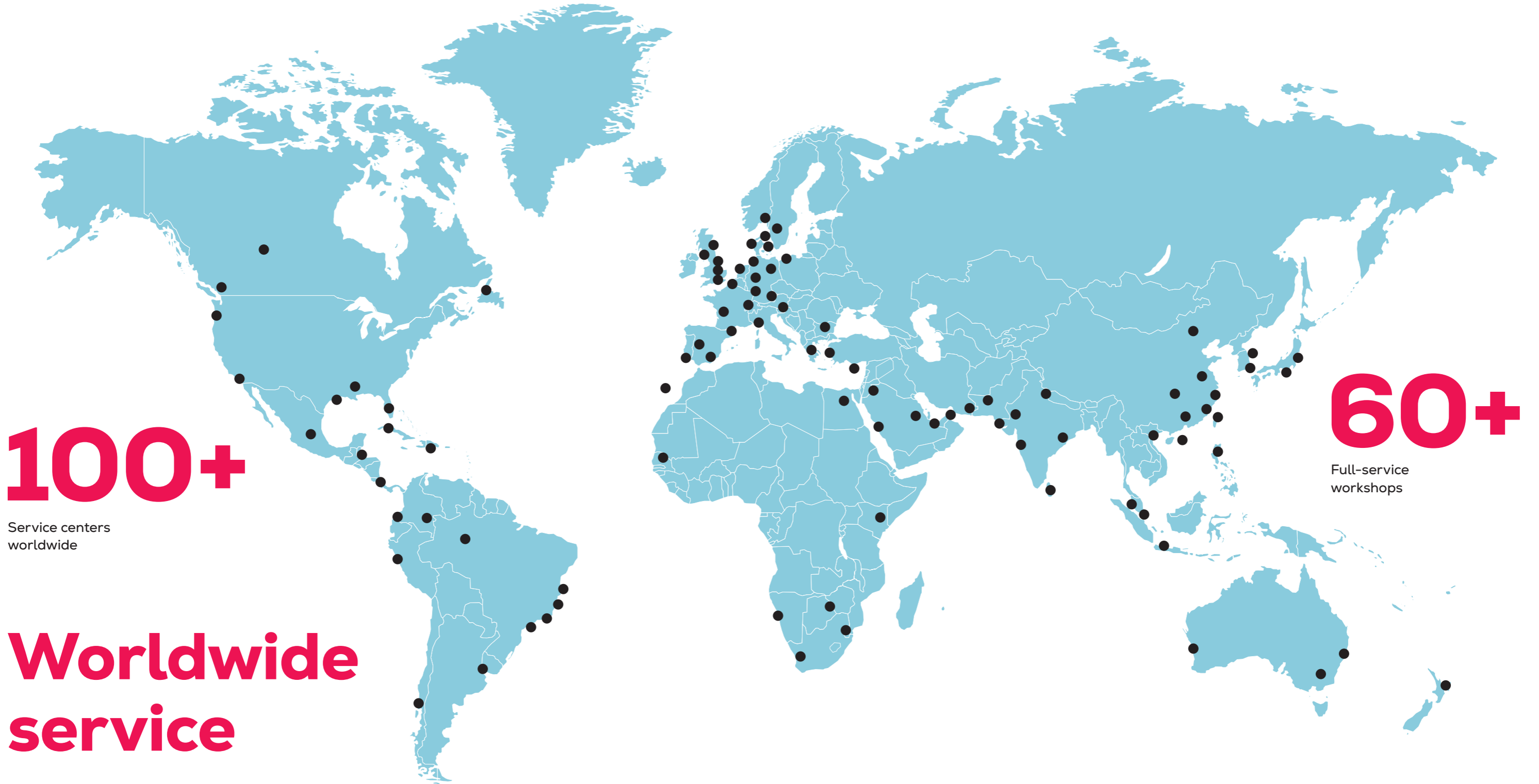

100+

Service centers worldwide

Worldwide service

We offer retrofit and upgrade services to bring propellers, propulsion systems, engines, and turbochargers already in service up to the very latest standards of performance and efficiency.

Using the latest digital technology, we enable you to maximize the performance and availability of your Everllence equipment by accessing real-time data analysis, remote support, and rapid solutions.

We also offer an extensive range of training courses at PrimeServ ACADEMIES around the world.

60+

Full-service workshops

Our service does not vary according to location. We know that a vessel may be built in Asia, operated in Europe for ten years, and then move to Africa for the next decade.

That does not alter our focus on fast delivery of strategic spare parts, a comprehensive approach, or our tailored Propeller Maintenance Concept.

For more information please visit www.everllence.com/services

Contact us
to propel your
business forward



Contact us directly at info-frh@everllence.com
or scan/click QR codes below for more information:



Propeller & aft ship

For propeller information,
contacts, and downloads.



Propeller Maintenance Concept

Learn how to protect your
investment and stay competitive.



Retrofit & modernization

Explore our retrofit and upgrade
solutions and benefits.

Everllence

Everllence

Niels Juels Vej 15
9900 Frederikshavn
Denmark
P +45 96 20 41 00
info-frh@everllence.com
www.everllence.com

MAN Energy Solutions SE has been renamed to Everllence SE and its products are being rebranded from "MAN" and/or "MAN Energy Solutions" to "Everllence". As this is an ongoing process, any reference to "MAN" and/or "MAN Energy Solutions" is actually a reference to "Everllence".

All data provided in this document is non-binding. This data serves informational purposes only and is not guaranteed in any way. Depending on the subsequent specific individual projects, the relevant data may be subject to changes and will be assessed and determined individually for each project. This will depend on the particular characteristics of each individual project, especially specific site and operational conditions. (1510-0278-02)

Copyright © Everllence.
EVR 000419EN-260200, GKM-FRH